

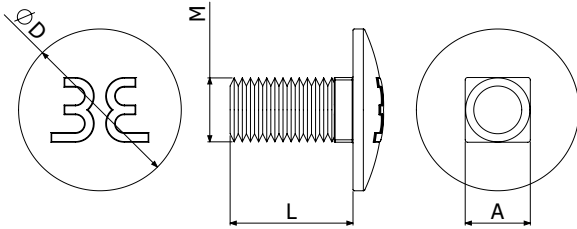

**CHARACTERISTICS**



Models: B1, B2, B3.

Finishes: EZ, HDG, ss304.

Characteristics:

- Rounded head without edges
- Recessed locking square (according to DIN 603 standard) adapted to the thickness of the trays.

Dimensions:

MODEL	Finish	M(mm)	L (mm)	D (mm)	A (mm)	T (N-m)
B1	EZ/HDG	6	14	14	7	6
	ss304/ss316	6	20	14	7	6
B2	EZ/HDG	8	15	20	8	15
	ss304/ss316	8	15	20	8	15
B3	HDG	10	22	25	10	35
	ss304/ss316	10	22	25	10	35

**USE INSTRUCTIONS**

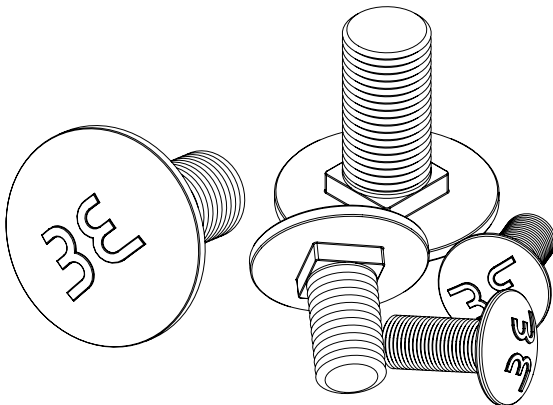

- Bolts B1, B2 and B3 are the ideal solution for fixing cable trays.
- The locking square does not require wrench to hold the screw head while tightening the nut.
- The reduced height of the square is adjusted to allow the fixing of suitable sheet thicknesses (DIN603 standard bolts are not suitable for fixing cable trays).
- Rounded head without edges prevents damage of cables.
- Bolts B1 are used to fix the BASORTRAY trays and their accessories between them (joints) and to the supports.
- Bolts B2 are used to fix the BASORTRAV trays and their accessories as well as in various support solutions (C-PC gusset, SCR to C-PC or SUL, etc.).
- Bolts B3 are used to fix BASORTRAV trays with large distance between posts and high load bearing solutions.